

**Race Track Nature Preserve (Village-owned land) Safety Enhancement Proposals**  
Presentation to/Request for Approval from Board of Trustees, April 19, 2023

3 work components:

1. Tuxedo Road entrance: elephant drain concrete cover.
2. East Lake Stable Rd entrance: cedar wood handrail at steps.
3. Tuxedo Road entrance: rustic style cedar wood gates.

We have reached out to three contractors. Indicative of the magnitude of cost is the first bid we received for a total fee of approx. \$9,000 (labor \$4,230, estimated materials \$4,660). We await response from the others. The projects will be paid for from donations to the Race Track Preserve. The DPW will need to be involved to remove the existing elephant drain logs and entrance iron pole. Timetable of work will be determined by DPW/Building Department/selected contractor.

The projects will be submitted for review by the Board of Architectural Review.

We request the BOT's permission for this work to take place on this Village-owned land and to allow the DPW to be involved as described above.

**Proposed work locations indicated by green dots**

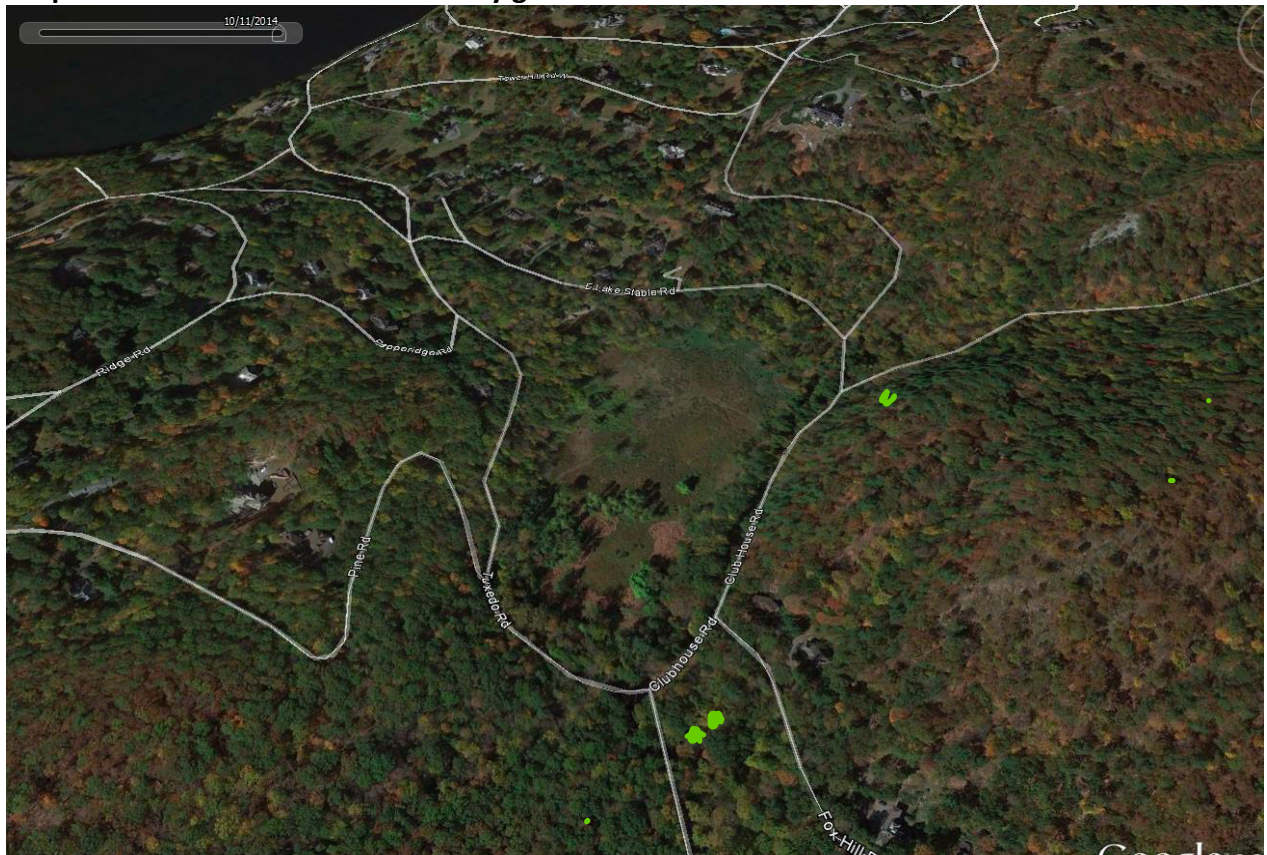



## 1. Tuxedo Road entrance: elephant drain concrete cover

The elephant drain collects all excess water from the flat basin before discharging it into Augusta Brook. The opening measures 16'W x 10'L x 30+'D (see 3<sup>rd</sup> drain photo.) It is currently covered by logs which have eroded. To prevent visitors, pets or wildlife from accidentally falling into the drain, we propose to put custom concrete covers over the opening. The concrete slabs will be poured on site and put over the opening, after the DPW has removed the existing logs.

### Existing condition/elephant drain





Interior of elephant drain: first level approx. 15' deep, second level another 15'?





Proposed custom concrete cover

RACK TRACK PIT VAULT

3/23/23

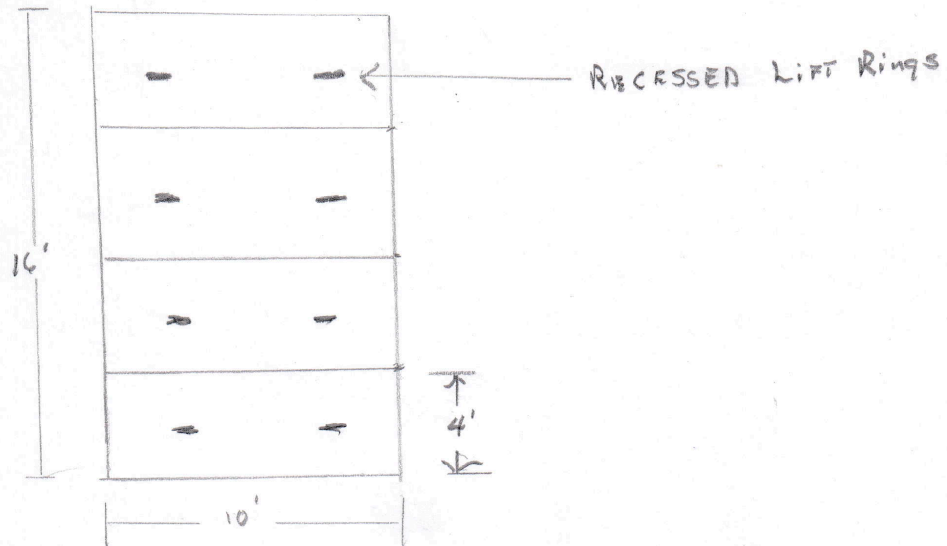

Construct 4 Concrete SLABS 4' w x 10' long

4" THICK SLABS WITH REINFORCING RODS + 2 LIFT BARS  
ON EACH SLAB

CONCRETE SLAB

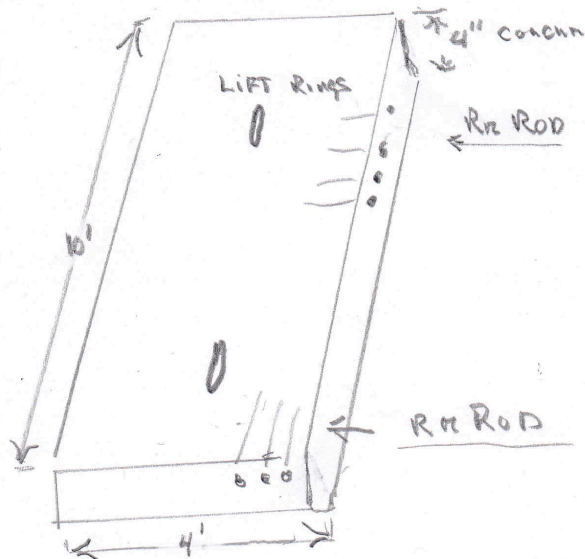

2



## 2. East Lake Stable Road north entrance: cedar wood handrail at stone steps

The native stone steps at the end of the short trail leading into the Race Track Preserve are uneven. Many residents have requested a handrail. The proposed 36' high cedar wood rail with concrete footing will be installed on the right side going downhill.

### Existing condition/north entrance steps





**Existing condition/north entrance steps**



**Similar cedar wood handrail at a Tuxedo Park property**





### 3. Tuxedo Road entrance rustic style cedar wood gates

Currently, a rusted iron pole at the entrance stops unauthorized vehicles from entering the Preserve. We propose to replace this barrier with cedar wood rustic style gates more consistent with Tuxedo Park's quality construction and complimenting the wood guard rails along Tuxedo Road. The new gates will be wide enough for access by DPW vehicles (12').

#### Existing condition/Tuxedo Road entrance barrier





Proposed rustic style cedar wood gates

3/23/23

RACE TRACK RUSTIC GATES

1. Support Posts 6" CEDAR. HORIZONTAL + VERTICAL POSTS 6" CEDAR
2. Rustic Hand Wound Hinges + Gate Latch

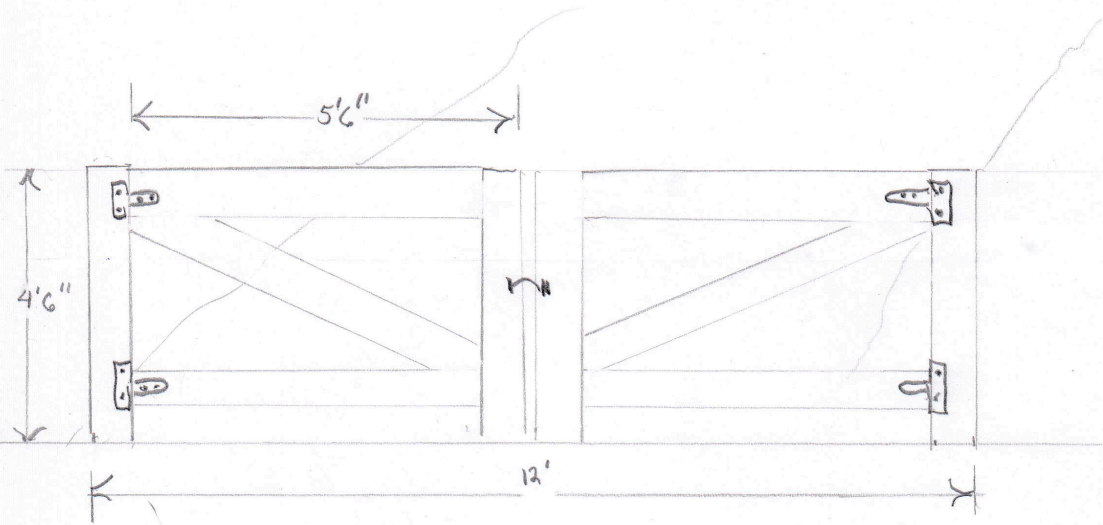

①